

Technical data sheet



Product features

Chip dump scuttle heating from above infrared heat lamp

| | | |
|--------------|-----------------|----------|
| Model | SAP Code | 00004881 |
|--------------|-----------------|----------|



- Drain: No
- Maximum device temperature [°C]: 90
- Minimum device temperature [°C]: 30
- Heating location: Upper

| | | | |
|------------------------|----------|----------------------------|--------------------|
| SAP Code | 00004881 | Net Weight [kg] | 5.50 |
| Net Width [mm] | 329 | Power electric [kW] | 0.500 |
| Net Depth [mm] | 555 | Loading | 230 V / 1N - 50 Hz |
| Net Height [mm] | 342 | | |

Technical data sheet



Technical drawing

Chip dump scuttle heating from above infrared heat lamp

| | | |
|--------------|-----------------|----------|
| Model | SAP Code | 00004881 |
|--------------|-----------------|----------|

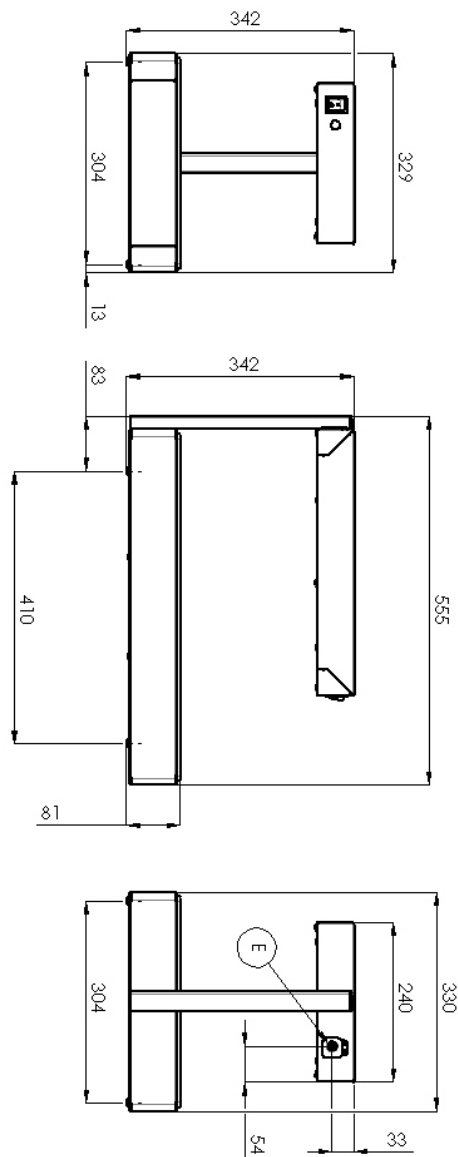

Technical data sheet



Product benefits

Chip dump scuttle heating from above infrared heat lamp

Model

SAP Code

00004881

1

All-stainless steel bathtub

long life
resistance of AISI 304 stainless steel material
the material does not cut

- savings on service interventions
- easier and faster operation

2

Degree of protection of the control elements IPX4

maintenance-free system
resistance to splash water
long life

- savings on service interventions
- easy cleaning and maintenance of equipment

3

Upper heating

radiant heat from above as well

- food heated quickly and evenly

Technical data sheet



Technical parameters

Chip dump scuttle heating from above infrared heat lamp

Model

SAP Code

00004881

1. SAP Code:

00004881

2. Net Width [mm]:

329

3. Net Depth [mm]:

555

4. Net Height [mm]:

342

5. Net Weight [kg]:

5.50

6. Gross Width [mm]:

450

7. Gross depth [mm]:

575

8. Gross Height [mm]:

330

9. Gross Weight [kg]:

7.00

10. Device type:

Electric unit

11. Construction type of device:

Table top

12. Power electric [kW]:

0.500

13. Loading:

230 V / 1N - 50 Hz

14. Protection of controls:

IPX4

15. Indicators:

operation and warm-up

16. Device heating type:

Infrared emitter

17. Maximum device temperature [°C]:

90

18. Minimum device temperature [°C]:

30

19. Adjustable feet:

Yes

20. False bottom:

No

21. Drain:

No

22. Number of GN / EN:

1

23. GN / EN size in device:

GN 1/1

24. GN device depth:

65

25. Heating location:

Upper